

Technical data sheet

Product features



Electric grill water

Model

SAP Code

00013574

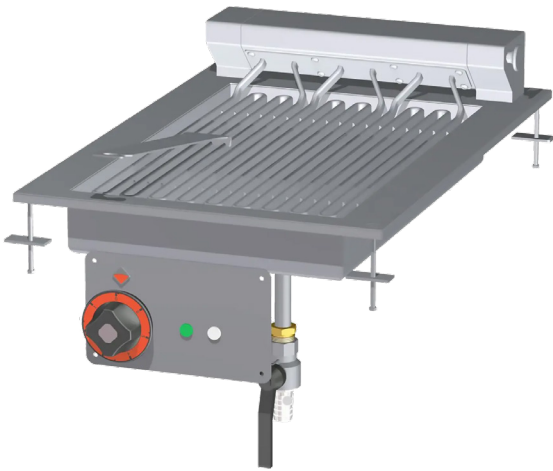

- Griddle dimensions [mm x mm]: 400 x 600
- Grid size [mm x mm]: 270 x 430

SAP Code	00013574	Power electric [kW]	4.080
Net Width [mm]	400	Loading	400 V / 3N - 50 Hz
Net Depth [mm]	600	Griddle dimensions [mm x mm]	400 x 600
Net Height [mm]	300	Grid size [mm x mm]	270 x 430
Net Weight [kg]	25.00		

Technical data sheet

Technical drawing



Electric grill water

Model

SAP Code

00013574

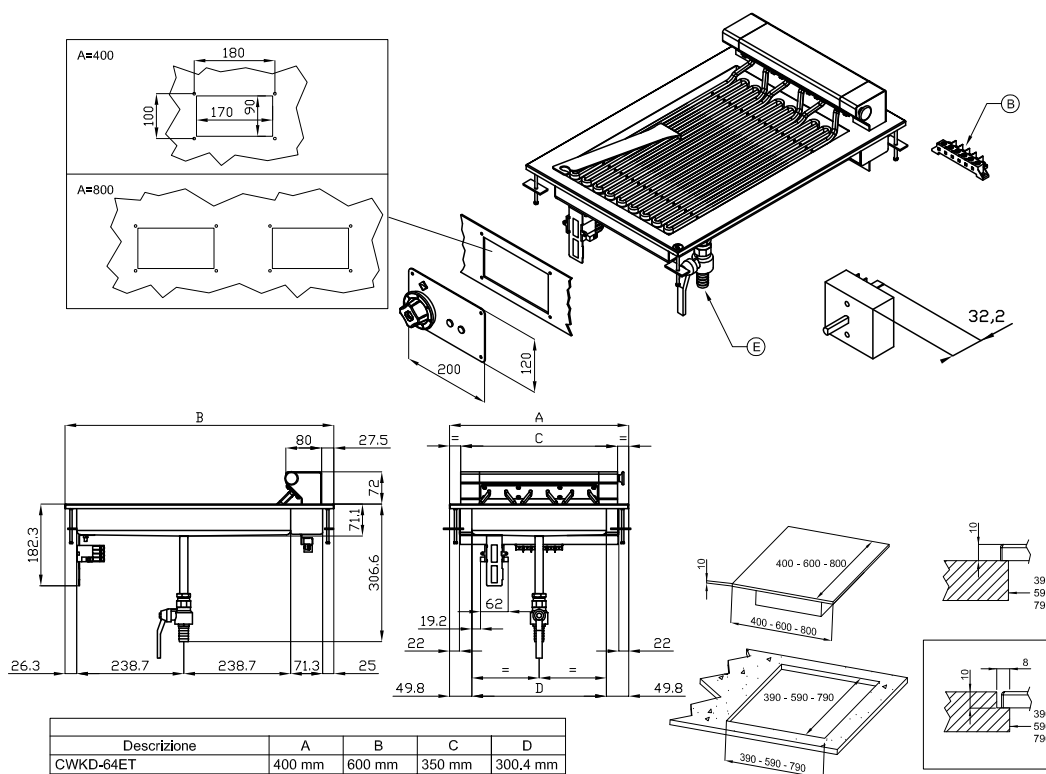

A	Data plate		B	Electrical connection	
E	Water drainage	Ø20mm			

Technical data sheet

Technical parameters



Electric grill water

Model

SAP Code

00013574

1. SAP Code:

00013574

2. Net Width [mm]:

400

3. Net Depth [mm]:

600

4. Net Height [mm]:

300

5. Net Weight [kg]:

25.00

6. Gross Width [mm]:

430

7. Gross depth [mm]:

690

8. Gross Height [mm]:

540

9. Gross Weight [kg]:

30.00

10. Device type:

Electric unit

11. Construction type of device:

Drop-in

12. Power electric [kW]:

4.080

13. Loading:

400 V / 3N - 50 Hz

14. Indicators:

operation and warm-up

15. Number of power control stages:

6

16. Griddle dimensions [mm x mm]:

400 x 600

17. Grid size [mm x mm]:

270 x 430

18. Grid shape:

the grid made up of flat heaters allows food to be placed directly on it, the fat from the food flows under the heaters into the water bath

19. Uniform heating:

Yes

20. Cross-section of conductors CU [mm²]:

1

– Výkon (kW): 3,7-5 (230 V); 6,4-8,7 (400 V)